



Selection: Open Screw Compressors OS

Input Values

Compressor model	OSKA5361-K	Speed	2900 /min
Refrigerant	R717	Useful superheat	100%
Reference temperature	Dew point temp.	Additional cooling	Automatic
Liq. subc. (in condenser)	0 K	Max. discharge gas temp.	80,0 °C
Suct. gas superheat	1,00 K	Cooling capacity	100 %
Operating mode	Standard		

Result

Q [W]	Cooling capacity	Qac [kW]	Additional cooling
P [kW]	Power input	tcu [°C]	Liquid temp.
COP [-]	COP/EER	pm [bar(a)]	ECO pressure
mLP [kg/h]	Mass flow LP	Qsc [kW]	sub cooler capacity (ECO)
mHP [kg/h]	Mass flow HP		

tc	to	10°C	5°C	0°C	-5°C	-10°C	-15°C	-20°C	-25°C
30°C	Q [W]	164540	137868	114569	94311	76780	61680	48734	--
	P [kW]	26,0	24,3	22,7	21,1	19,65	18,25	16,93	
	COP [-]	6,32	5,67	5,05	4,47	3,91	3,38	2,88	
	mLP [kg/h]	523	440	367	304	249	201	159,7	
	mHP [kg/h]	523	440	367	304	249	201	159,7	
	Qac [kW]	5,06	5,79	6,46	7,12	7,78	8,32	8,74	
	tcu [°C]	30,0	30,0	30,0	30,0	30,0	30,0	30,0	
	pm [bar(a)]	--	--	--	--	--	--	--	
	Qsc [kW]	--	--	--	--	--	--	--	
40°C	Q [W]	154653	129223	106995	87650	70891	56434	--	--
	P [kW]	31,1	29,1	27,2	25,4	23,7	22,0		
	COP [-]	4,97	4,44	3,94	3,46	3,00	2,57		
	mLP [kg/h]	513	431	358	295	240	192,1		
	mHP [kg/h]	513	431	358	295	240	192,1		
	Qac [kW]	11,92	12,41	12,79	13,08	13,27	13,35		
	tcu [°C]	40,0	40,0	40,0	40,0	40,0	40,0		
	pm [bar(a)]	--	--	--	--	--	--		
	Qsc [kW]	--	--	--	--	--	--		
50°C	Q [W]	142747	118879	97993	79790	63989	--	--	--
	P [kW]	36,5	34,3	32,2	30,1	28,1			
	COP [-]	3,91	3,46	3,05	2,65	2,28			
	mLP [kg/h]	496	415	344	281	227			
	mHP [kg/h]	496	415	344	281	227			
	Qac [kW]	20,8	20,6	20,3	19,97	19,54			
	tcu [°C]	50,0	50,0	50,0	50,0	50,0			
	pm [bar(a)]	--	--	--	--	--			
	Qsc [kW]	--	--	--	--	--			

-- No calculation possible (see message in single point selection)

*According to EN12900 (5K suction gas superheat, 0K liquid subcooling)

Application Limits Standard OSKA5361

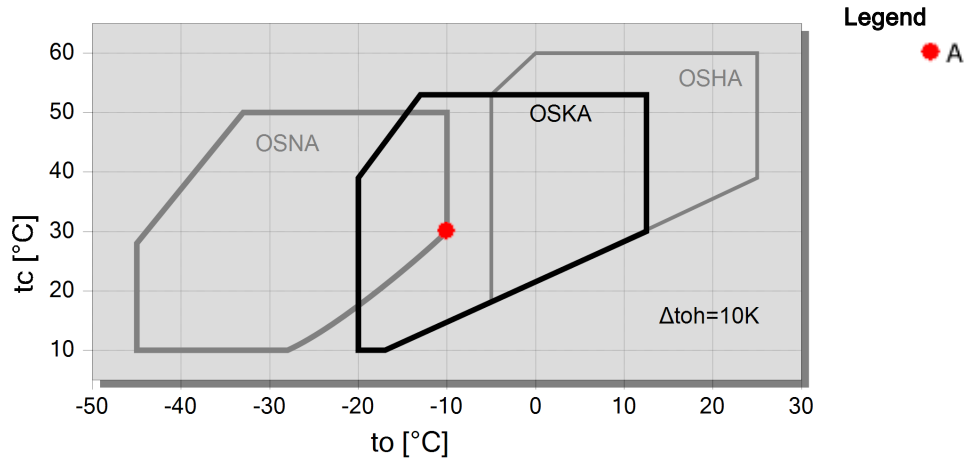



Technical Data: OSKA5361-K

Dimensions and Connections

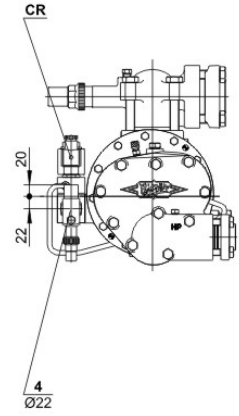
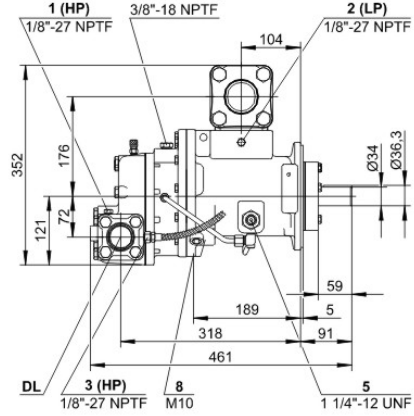
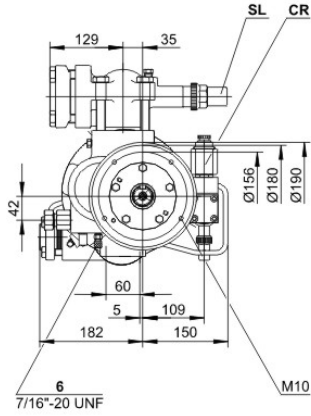



Technical Data

Technical Data

Displacement (2900 RPM 50 Hz)	118 m ³ /h
Displacement (3500 RPM 60 Hz)	142 m ³ /h
Allowed speed range	1450 .. 4500 min ⁻¹
Sens of rotation (compressor)	rechts / clockwise
Weight	65 kg
Max. pressure (LP/HP)	19 / 28 bar
Connection suction line	54 mm - 2 1/8"
Connection suction line (NH3)	DN 50
Connection discharge line	42 mm - 1 5/8"
Connection discharge line (NH3)	DN 40
Adapter for ECO (NH3)	DN 20 (Option)
Oil type NH3	Reniso KC68 , SHC 226E

Extent of delivery (Standard)

Suction shut-off valve	Standard
Pressure relief valve	Standard
Check valve	Standard
Oil injection kit	Standard
Built in oil filter	Standard
discharge gas temperature monitoring	SE-B3
Discharge gas temperature sensor	Standard
Protective charge	Standard

Available Options

Oil flow control	Option
Discharge shut-off valve	Option
ECO connection with shut-off valve	Option
Coupling housing	Option
Start unloading	Option
Capacity control	100-75% (Option)



Open Screw Compressors OS

OSK = Application for air-conditioning and medium temperature cooling.

OSN = Application for low temperature cooling.

OSH = Application for air-conditioning and heat pumps.

Notes regarding application limits (see "T.Data - Limits")

* Ranges are valid for standart operation and at full-load conditions.

* With high pressure conditions, part-laod operation is partly limited (see application limits in applications manual SH-500/SH-510).

* With Economizer operation the maximum admissible evaporation temperature is shifted by 10K downward (otherwise there is a danger of excessive compression and overlaod of the motor because of a higher mass flow). At pull-down conditions from higher evaporation temperatures, the ECO injection must remain closed until the evaporation temperature is below the maximum admissible value and a stable operation is achieved (e.g. control of the ECO solenoid valve by means of a low pressure cut-out). The use of the ECO-System with higher evaporation temperatures requires individual consultation with Bitzer.

OS53..OS74

* Capacity control with ECO operation at the same time is limited to one single regulating step (CR 75%). At CR 50% the ECO injection should be closed.

* Combined operation (ECO + CR 50%) is possible under certain conditions, control and system design, however, require individual consultation with Bitzer.

Motor Selection

The required driving motor is selected for starting conditions at direct start as well as at star-delta-start with start unloading (50% capcaity regulation). The starting conditions refer to the following defined operation points resp. to the maximum application limit of the compressor. Should the evaporation- or the condensing temperature of the plant be higher at the start, an individual motor selection is necessary.

Evaporation temperature for motor selection				
	HH	H	M	L
R134a	+20 °C	+12,5 °C	-5 °C	
R404A / R507A		+7,5 °C	-5 °C	-15 °C
R22		+12,5 °C	-5 °C	-10 °C
R407C		+12,5 °C	-5 °C	
NH ₃	+25 °C	+12,5 °C	-5 °C	-10 °C

The stated motor data refer to IEC motors at which the pull-up torque should not fall below 90% of the max. torque. In addition the following starting torque (referring to direct start) must be reached:

* open screw compressors 120%

Should the motor not fulfil these criteria, an individual selection is also necessary.

Lubricants and additional cooling for NH3 applications

	Type	Viscosity	Discharge gas (°C)	Oil injection (°C)
Reniso KM32	MO	32	ca. 60 .. max. 100	max. 50
Reniso KS46	MO	46	ca. 60 .. max. 80 (100 [1])	max. 60
Reniso KC68	MO	68	ca. 60 .. max. 80 (100 [1])	max. 60
Reflo 68A	MO (HT)	58	ca. 60 .. max. 80 (100 [1])	max. 60
SHC226E	PAO	68	ca. 60 .. max. 80 (100 [1])	max. 60

[1] 100 °C only after consultation with BITZER

Further information on the selection of lubricants can be found in the Application Manuals SH-500 and SH-510.

**Legend of connection positions according to "Dimensions":**

- 1 High pressure connection (HP)
Connection for high pressure switch (HP)
- 1a Additional high pressure connection (HP)
Not suitable for pressure switch or pressure transmitter!
- 1b Connection for high pressure transmitter (HP)
- 2 Low pressure connection (LP)
Connection for low pressure switch
- 2a Additional low pressure connection (LP)
- 2b Connection for low pressure transmitter (LP)
- 2c Low pressure connection for the minimum pressure differential control valve
- 3 Connection for discharge gas temperature sensor (HP)
- 4 Connection for economiser (ECO)
 HS.85: ECO valve with connection line (option)
 OS.85, OS.95, OS.105, HS.95: ECO valve (option)
- 5 Connection/valve for oil injection
- 6 Oil pressure connection
- 7 Oil drain (compressor or motor housing)
- 7a Oil drain (suction gas filter)
- 7b Oil drain from shaft seal (maintenance connection)
- 7c Oil drain hose (shaft seal)
- 8 Threaded bore for foot fastening
- 9 Threaded bore for pipe fixture (ECO and LI lines)
- 10 Maintenance connection for oil filter
- 11 Oil drain (oil filter)
- 13 Oil filter monitoring
- 14 Oil flow switch
- 15 Earth screw for housing
- 16 Pressure blow-off (oil filter chamber)
- 17 Maintenance connection for shaft seal
- 18 Liquid injection (LI)
- 19 Compressor module
- 20 Slider position indicator
- 21 Oil level switch
- 22 Oil pressure transmitter
- 23 Connection for oil and gas return (for systems with flooded evaporator adaptor optional)
- 24 Access to oil circulation restrictor
- 25 Oil inlet for shaft seal cooling
- 26 Oil outlet for shaft seal cooling
- 27 Temperature sensor in the shaft seal
- 28 Vibration sensor connection
- SL Suction gas line
- DL Discharge gas line

Dimensions can show tolerances according to EN ISO 13920-B.